

LOCK-N-STITCH Inc.
Casting Repair Specialists
1015 S. Soderquist Rd.
Turlock CA 95380

800-736-8261
209 632-2345
Fax 209-632-1740
www.locknstitch.com

Final Report

Date: 12-31-12

Part: Wartsila engine block W6L20

Inspected by: Brian Schoppet

1. Base metal

- cast iron
- ductile iron
- cast steel
- cast aluminum
- other _____

2. Machinability

- no previous repairs
- arc-welded
- brazed
- heat-related cracks
- other _____

3. Casting shape where cracked

- flat
- inside/outside corner
- radius
- other _____

4. Cause of damage

- impact
- heat
- freezing
- normal operation
- other _____

5. Length of crack/s

11 1/2" of crack

6. Material thickness

1" to 1 1/4" thick

7. Operating pressure

N/A

8. Operating temperature
200

9. Working environment
 hot
 cold
 safety concerns
describe: _____

 other _____

10. Remachining requirements
 bolt holes
 bearing bores
 machined surfaces
 other _____

13. Inspection method(s)
Visual and mag particle

14. Damage found:

Inspection door gasket surface was damaged with a piece of casting missing. Metal stitched a patch into place using our patented Castmaster stitching pins. Total of 11 1/2" of metal stitching was completed. Ranging from 1" thick to 1 1/4" thick

No cracks were discovered in the bottom of the cam box.

Ground and smoothed out all dings and dents.

See pictures below

11. Customer's needs
 permanent repair
 temporary repair
 turnaround time
describe: _____

 other _____

12. Accessibility
 room for the tools?
 room for the operator/s?
 need for disassembly?
describe: Good access

 other _____













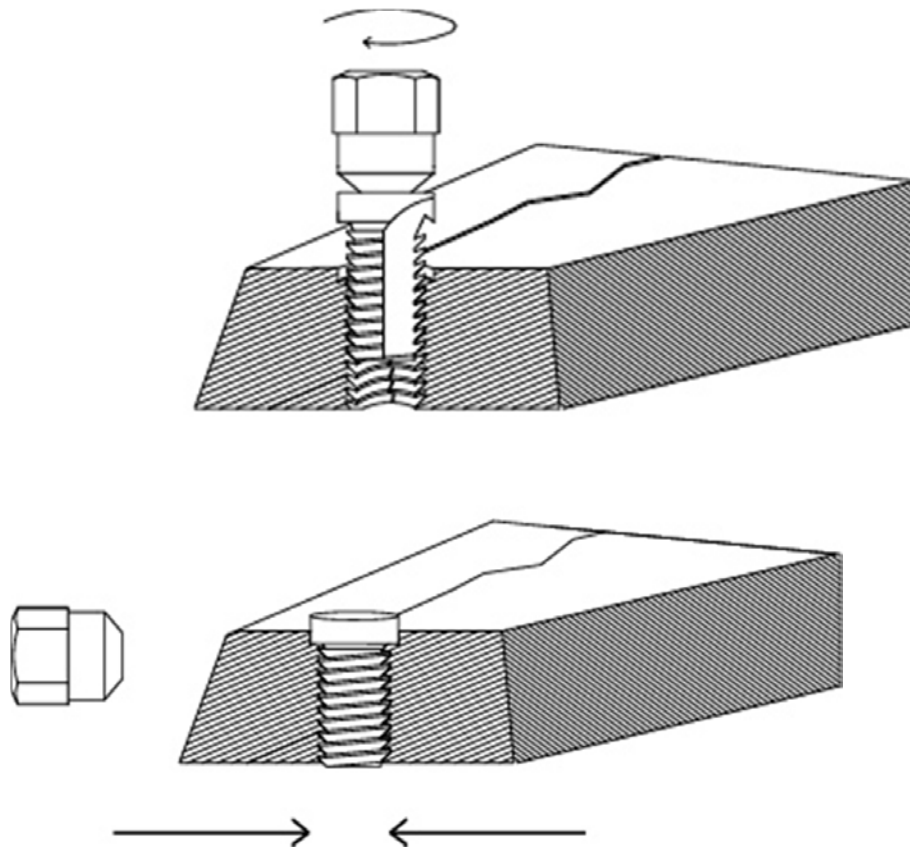

Castmaster Stitching pins for strength and seal

Warranty:

This limited warranty covers our materials and workmanship for the repair of your part. Disassembly and downtime are not covered by this warranty. The limited warranty is for a period of one year from the date of completion of the repair. If there should be any failure in our repair during that period of time due to faulty materials and or workmanship, we will again repair the part at our cost including all labor, materials and travel expense, or we could choose to refund the money you paid for the repair in part or full. We reserve the right to make the final decision whether to repair or refund. This is the limit of our liability. Be aware that we are not responsible for failures due to faulty installation or improper operation and maintenance of the part. If the problem that caused the original damage has not been remedied this warranty will become null and void.